

**1-Line, Unidirectional Transient Voltage Suppressors**

**Descriptions**

The ESD24B450TR is a Unidirectional TVS (Transient Voltage Suppressor). It is specifically designed to protect sensitive electronic components that may be subjected to ESD (Electrostatic Discharge), EFT (Electrical Fast Transients) and Lightning. It is particularly well-suited for cellular phones, portable device, digital cameras, power supplies and many other portable applications because of its small package and low weight.

The ESD24B450TR may be used to provide ESD protection up to  $\pm 30\text{kV}$  air discharge  $\pm 30\text{kV}$  contact discharge according to IEC61000-4-2, and withstand peak pulse current up to  $12.0\text{A}(8/20\mu\text{s})$  according to IEC61000-4-5.



**SOD-523**

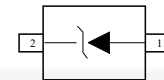

**Circuit diagram**

**Features**

- Stand-off voltage: 24 V Max
- Transient protection for each line according to  
IEC61000-4-2 (ESD):  $\pm 30\text{kV}$  air discharge  $\pm 30\text{kV}$  contact discharge  
IEC61000-4-4 (EFT): 40A (5/50ns)  
IEC61000-4-5 (surge): 12.0A(8/20 $\mu\text{s}$ )
- Solid-state silicon technology
- Low leakage current

**Applications**

- Cell phone handsets and accessories
- Personal Digital Assistants (PDAs)
- Notebooks, Desktops, and Servers
- Portable Instrumentation
- Digital Cameras
- MID/CAR DVD/MP3/MP4/PMP Players

**Order information**

Device	Package	Shipping
ESD24B450TR	SOD-523	3000/Tape&Reel

**Absolute maximum ratings**

Parameter	Symbol	Rating	Unit
Peak pulse current ( $t_p = 8/20\mu s$ )	$I_{PP}$	12.0	A
ESD according to IEC61000-4-2 air discharge	$V_{ESD}$	$\pm 30$	kV
ESD according to IEC61000-4-2 contact discharge		$\pm 30$	
Operation junction temperature	$T_J$	-55~150	$^{\circ}C$
Lead temperature	$T_L$	260	$^{\circ}C$
Storage temperature	$T_{STG}$	-55~150	$^{\circ}C$

**Electrical characteristics (TA=25 $^{\circ}C$  , unless otherwise noted)**

Parameter	Symbol	Condition	Min.	Typ.	Max.	Unit
Reverse stand-off voltage	$V_{RWM}$				24.0	V
Reverse leakage current	$I_R$	$V_{RWM} = 24V$			1.0	$\mu A$
Reveres breakdown voltage	$V_{BR12}$	$I_T = 1mA$	26.0	28.0	30.0	V
Clamping voltage	$V_C$	$I_{pp} = 1A$ $t_p = 8/20\mu s$			32.0	
		$I_{pp} = 12.0A$ $t_p = 8/20\mu s$			36.0	V
Junction capacitance	$C_J$	$V_R = 0V, f = 1MHz$		50.0	70.0	pF

**Electrical performance curve**

Symbol	Parameter
$I_{PP}$	Maximum Reverse Peak Pulse Current
$V_C$	Clamping Voltage @ $I_{PP}$
$V_{RWM}$	Working Peak Reverse Voltage
$I_R$	Maximum Reverse Leakage Current @ $V_{RWM}$
$I_T$	Test Current
$V_{BR}$	Breakdown Voltage @ $I_T$
$I_F$	Forward Current
$V_F$	Forward Voltage @ $I_F$

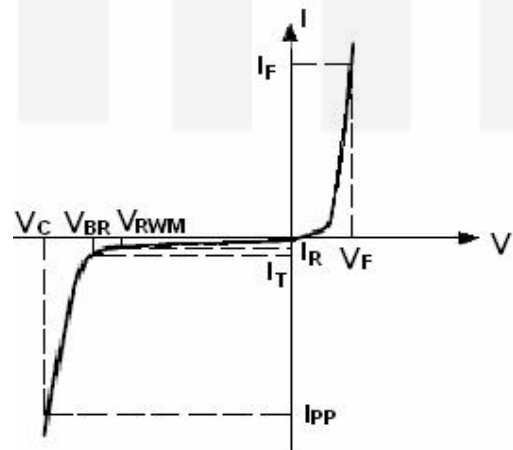

Typical characteristics ( $T_A=25^\circ\text{C}$ , unless otherwise noted)

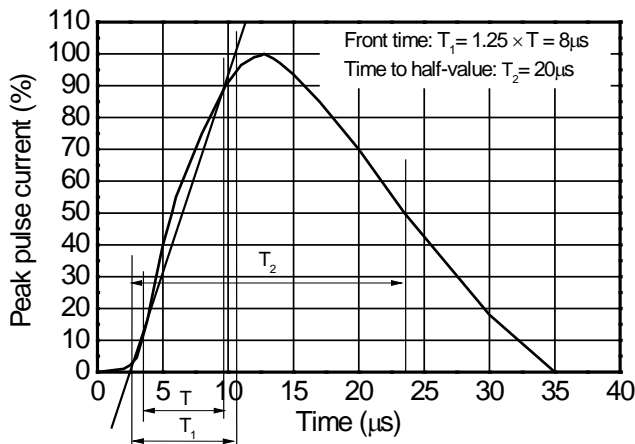

8/20 $\mu\text{s}$  waveform per IEC61000-4-5

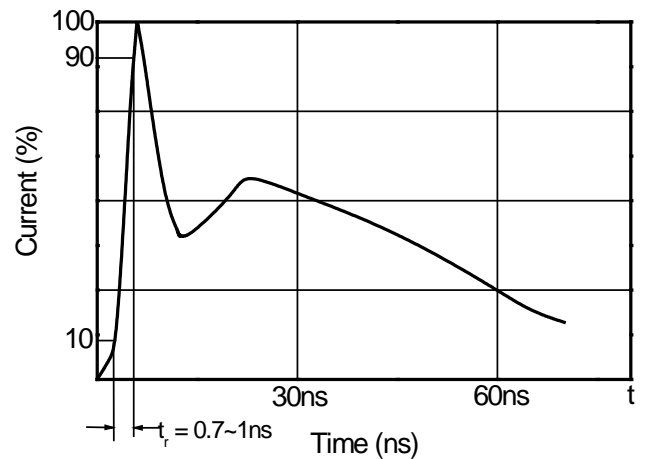

Contact discharge current waveform per IEC61000-4-2

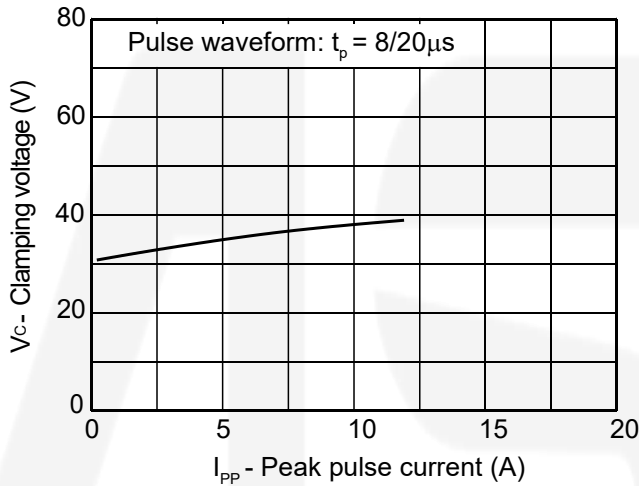

Clamping voltage vs. Peak pulse current

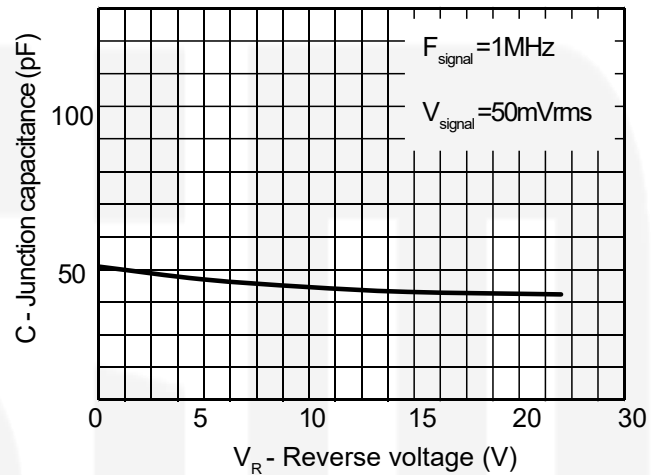

Capacitance vs. Reverses voltage

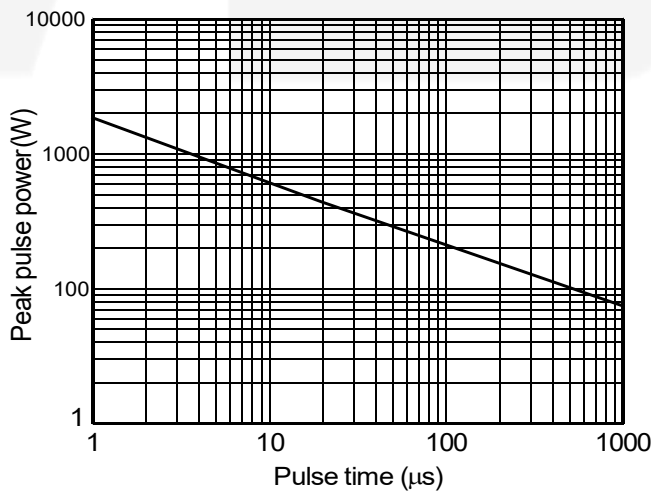

Non-repetitive peak pulse power vs. Pulse time

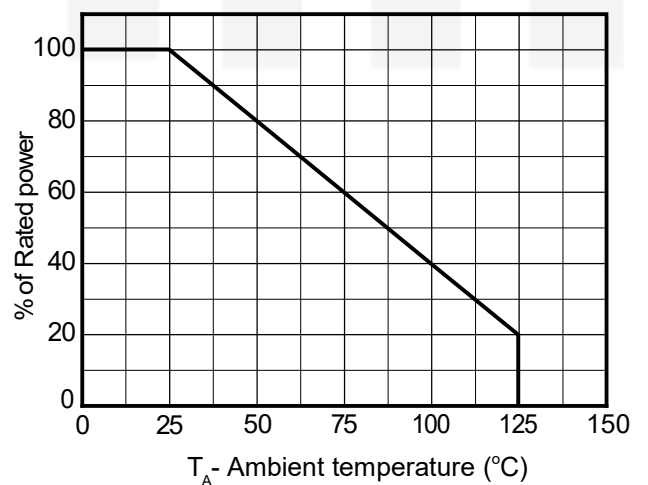

Power derating vs. Ambient temperature

ESD clamping test setup and waveforms

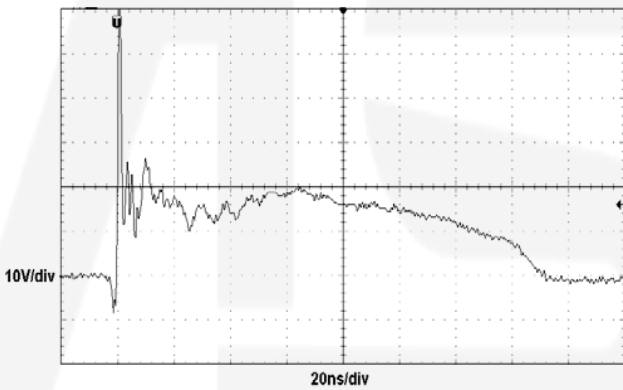
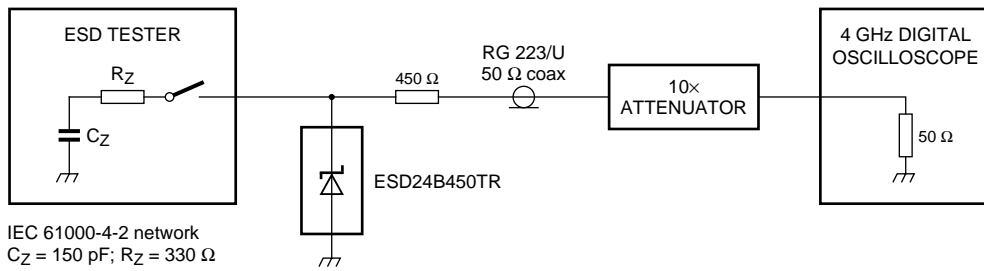

**ESD clamping**  
(+8kV contact discharge per IEC61000-4-2)

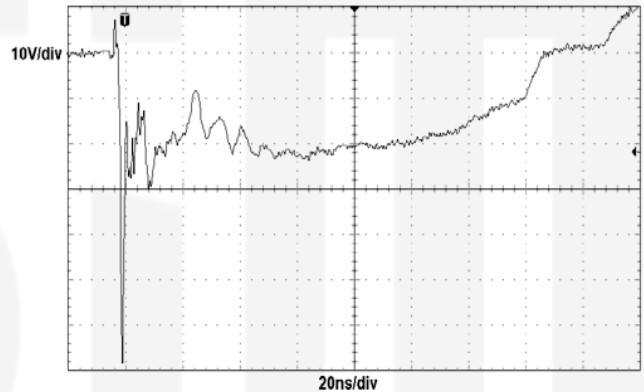

**ESD clamping**  
(-8kV contact discharge per IEC61000-4-2)

Package outline dimensions

SOD-523

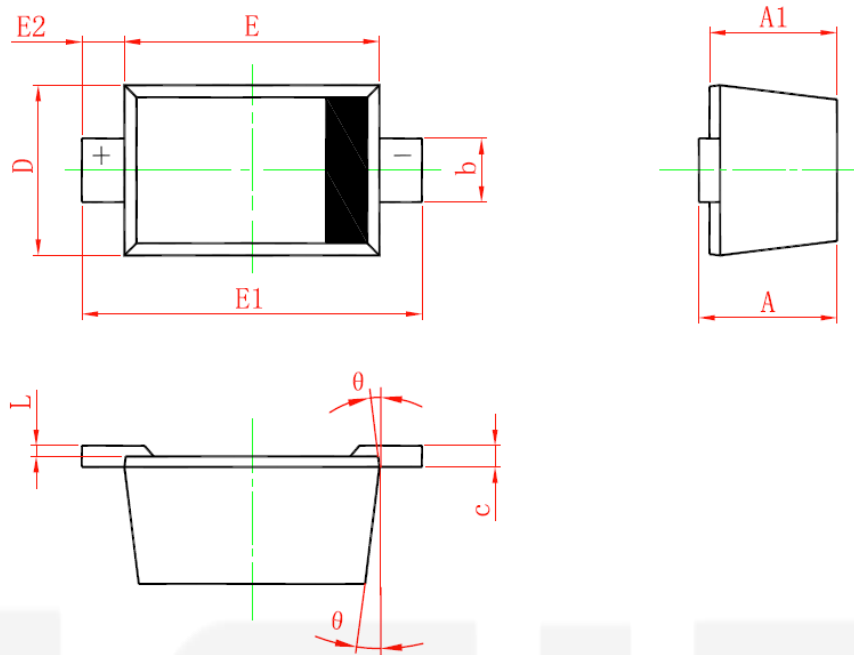

Symbol	Dimensions in millimeter		
	Min.	Typ.	Max.
A	0.510	0.640	0.770
A1	0.500	0.600	0.700
b	0.250	0.300	0.350
c	0.080	0.115	0.150
D	0.750	0.800	0.850
E	1.100	1.200	1.300
E1	1.500	1.600	1.700
E2	0.200 Ref		
L	0.010	0.040	0.070
θ	7° Ref		

Recommend land pattern (Unit: mm)

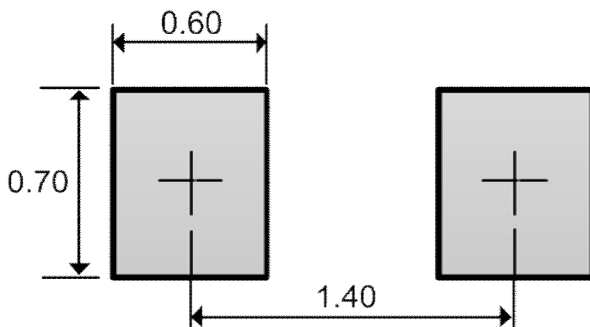

Note: This land pattern is for your reference only. Actual pad layouts may vary depending on application.