

## 1-Line, Uni-directional, Transient Voltage Suppressors

### Descriptions

The ESD5B600TR is a Uni-directional TVS (Transient Voltage Suppressor). It is specifically designed to protect sensitive electronic components that may be subjected to ESD (Electrostatic Discharge), EFT (Electrical Fast Transients) and Lightning. It is particularly well-suited for cellular phones, portable device, digital cameras, power supplies and many other portable applications because of its small package and low weight.

The ESD5B600TR may be used to provide ESD protection up to  $\pm 30\text{KV}$  Air,  $\pm 30\text{KV}$  contact compliance to IEC61000-4-2, and withstand peak pulse current up to 9.0A (8/20 $\mu\text{s}$ ) according to IEC61000-4-5.



SOD-523

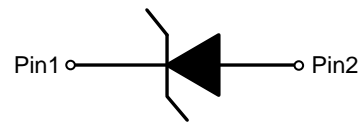

Circuit diagram

### Features

- Stand-off voltage: 5.0VMax
- Transient protection for each line according to IEC61000-4-2 (ESD):  $\pm 30\text{KV}$  Air,  $\pm 30\text{KV}$  contact IEC61000-4-4(EFT): 40 A (5/50 ns) IEC61000-4-5 (Surge): 9.0 A (8/20 $\mu\text{s}$ )
- Solid-state silicon technology
- Low leakage current

### Applications

- Cell phone handsets and accessories
- Personal Digital Assistants (PDAs)
- Notebooks, Desktops, and Servers
- Portable Instrumentation
- Digital Cameras
- CAR/MID DVD/MP3/MP4/PMP Players

### Order information

Device	Marking	Package	Shipping
ESD5B600TR	ZF	SOD523	3000/Tape&Reel

**Absolute maximum ratings**

Parameter	Symbol	Rating	Unit
Peak pulse current ( $t_p = 8/20\mu s$ )	$I_{PP}$	9.0	A
ESD according to IEC61000-4-2 air discharge	$V_{ESD}$	$\pm 30$	kV
ESD according to IEC61000-4-2 contact discharge		$\pm 30$	
Operation junction temperature	$T_J$	-50~125	$^{\circ}C$
Lead temperature	$T_L$	260	$^{\circ}C$
Storage temperature	$T_{STG}$	-65~150	$^{\circ}C$

**Electrical characteristics (TA=25  $^{\circ}C$ , unless otherwise noted)**

Parameter	Symbol	Condition	Min.	Typ.	Max.	Unit
Reverse stand-off voltage	$V_{RWM}$				5.0	V
Reverse leakage current	$I_R$	$V_{RWM} = 5.0V$			0.2	$\mu A$
Reveres breakdown voltage	$V_{BR12}$	$I_T = 1mA$	6.0		8.3	V
Clamping voltage	$V_C$	$I_{pp} = 9.0A$ $t_p = 8/20\mu s$			12.0	V
Junction capacitance	$C_J$	$V_R = 0V$ , $f = 1MHz$		60.0	80.0	pF

**Electrical performance curve**

Symbol	Parameter
$V_{RWM}$	Peak Reverse Working Voltage
$I_R$	Reverse Leakage Current @ $V_{RWM}$
$V_{BR}$	Breakdown Voltage @ $I_T$
$I_T$	Test Current
$I_{PP}$	Maximum Reverse Peak Pulse Current
$V_C$	Clamping Voltage @ $I_{PP}$
$I_F$	Forward Current
$V_F$	Forward Voltage @ $I_F$

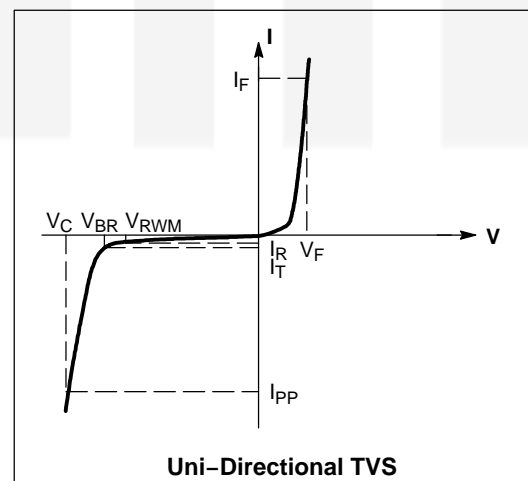

Typical characteristics ( $T_A=25^\circ\text{C}$ , unless otherwise noted)

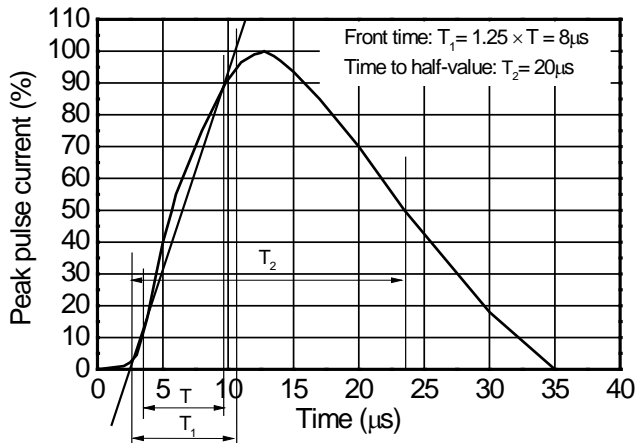

8/20 $\mu\text{s}$  waveform per IEC61000-4-5

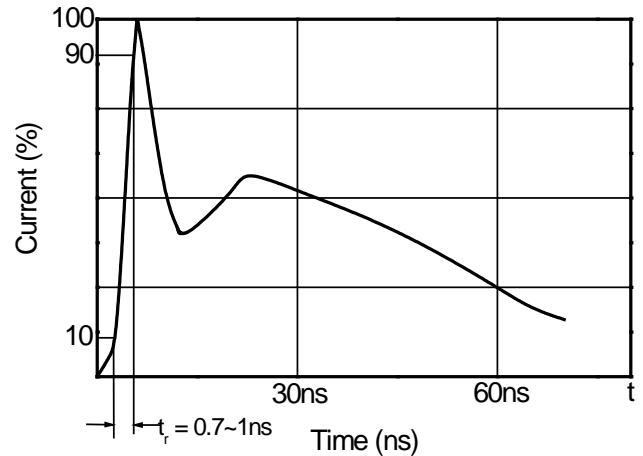

Contact discharge current waveform per IEC61000-4-2

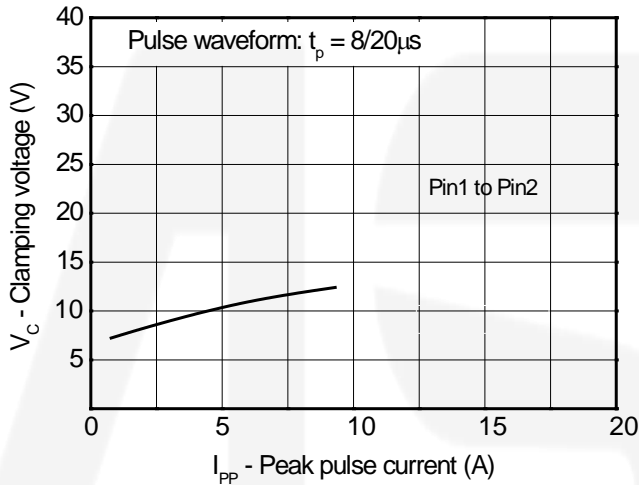

Clamping voltage vs. Peak pulse current

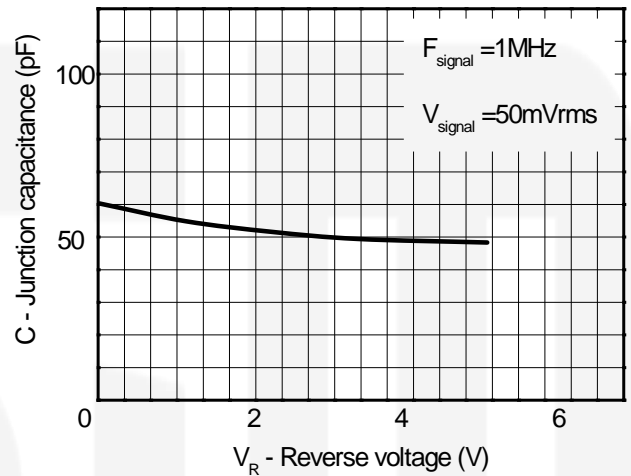

Capacitance vs. Reverses voltage

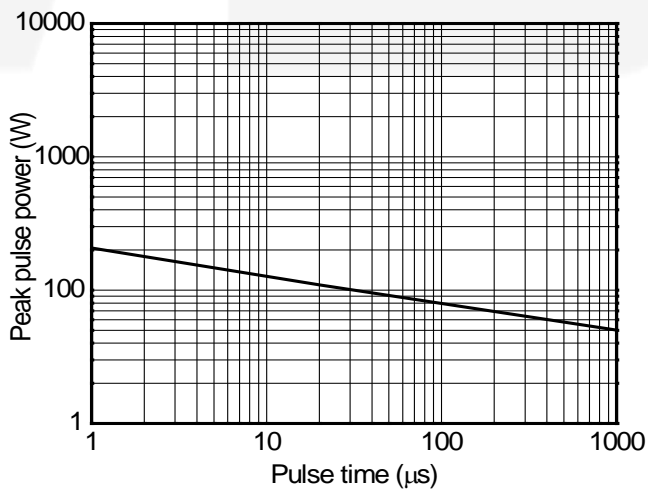

Non-repetitive peak pulse power vs. Pulse time

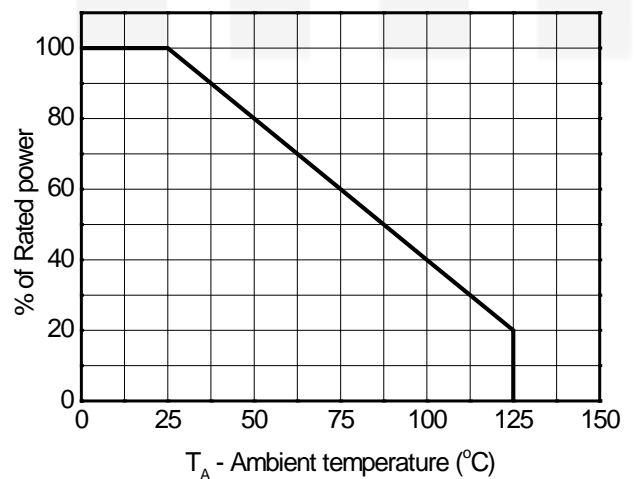

Power derating vs. Ambient temperature

ESD clamping test setup and waveforms

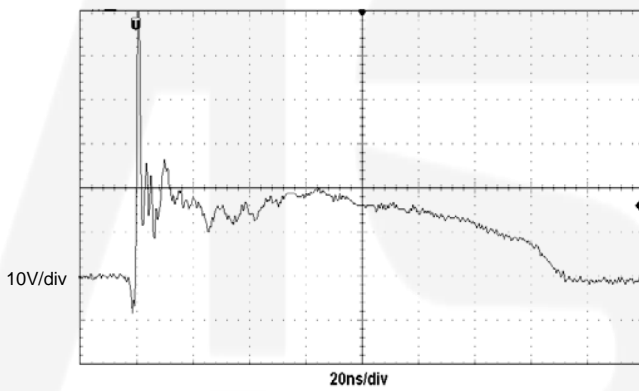
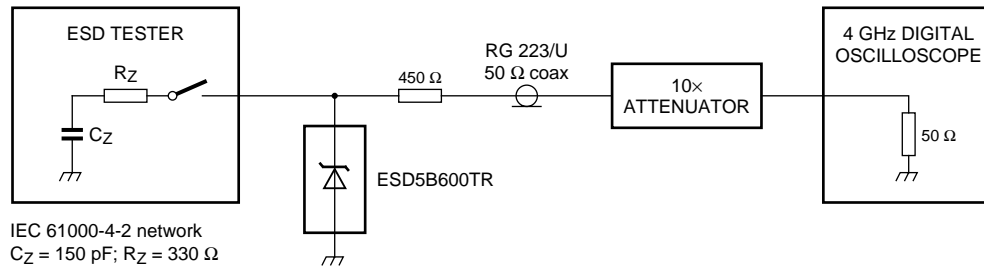

**ESD clamping**  
**(+8kV contact discharge per IEC61000-4-2)**

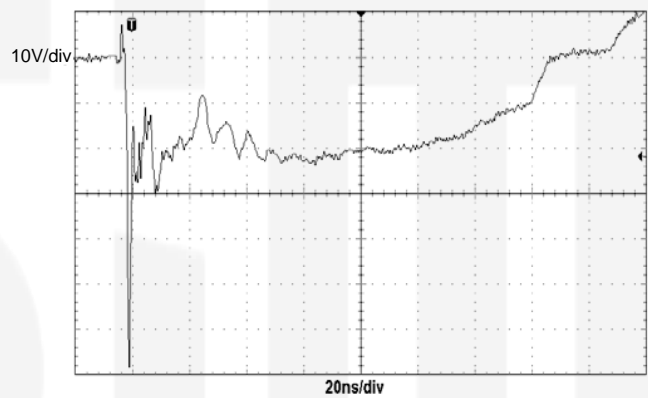

**ESD clamping**  
**(-8kV contact discharge per IEC61000-4-2)**

Package outline dimensions

SOD-523

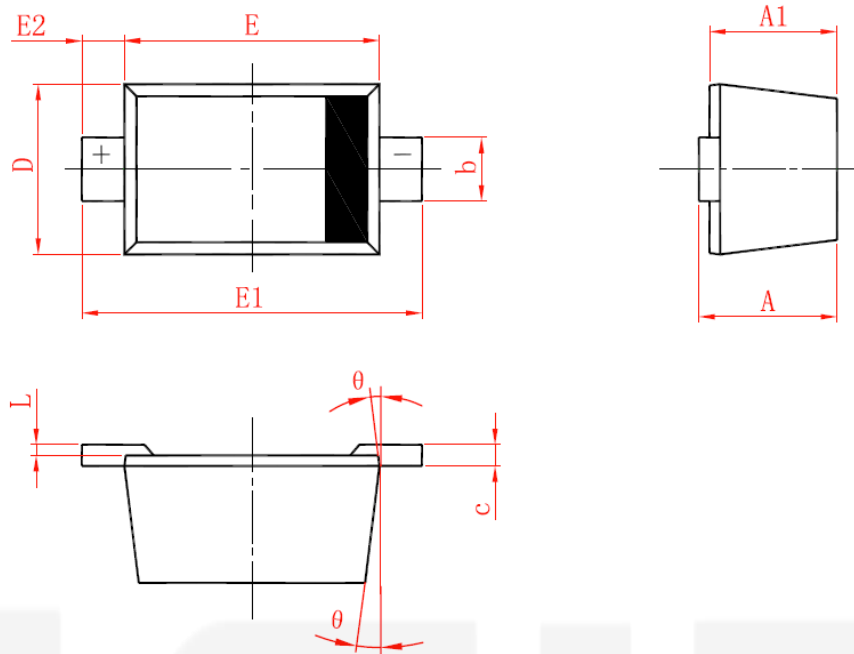

Symbol	Dimensions in millimeter		
	Min.	Typ.	Max.
A	0.510	0.640	0.770
A1	0.500	0.600	0.700
b	0.250	0.300	0.350
c	0.080	0.115	0.150
D	0.750	0.800	0.850
E	1.100	1.200	1.300
E1	1.500	1.600	1.700
E2	0.200 Ref		
L	0.010	0.040	0.070
θ	7° Ref		

Recommend land pattern (Unit: mm)

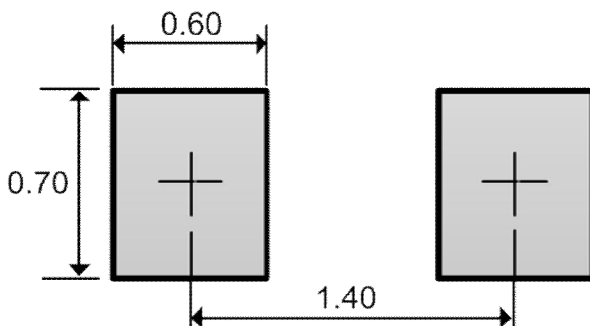

Note: This land pattern is for your reference only. Actual pad layouts may vary depending on application.