

1-Line, Bi-directional, Transient Voltage Suppressors

Descriptions

The ESD12B100TA is a bi-directional TVS (Transient Voltage Suppressor). It is specifically designed to protect sensitive electronic components that may be subjected to ESD (Electrostatic Discharge), EFT (Electrical Fast Transients) and Lightning. It is particularly well-suited for cellular phones, portable device, digital cameras, power supplies and many other portable applications because of its small package and low weight.

The ESD12B100TA may be used to provide ESD protection up to $\pm 30\text{kV}$ air discharge $\pm 30\text{kV}$ contact discharge according to IEC61000 - 4 - 2, and withstand peak pulse current up to 5.0A (8/20 μs) according to IEC61000-4-5.

The ESD12B100TA is available in SOD-523 package. Standard products are Pb-free and Halogen-free.



SOD-523

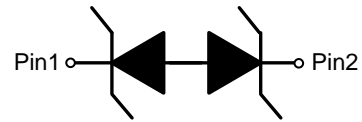

Circuit diagram

Features

- Stand-off voltage: $\pm 12\text{V}$ Max
- Transient protection for each line according to IEC61000-4-2 (ESD): $\pm 30\text{kV}$ air discharge $\pm 30\text{kV}$ contact discharge IEC61000-4-4 (EFT): 40A (5/50ns) IEC61000-4-5 (surge): 5.0A(8/20 μs)
- Solid-state silicon technology
- Low leakage current

Applications

- Cell phone handsets and accessories
- Personal Digital Assistants (PDAs)
- Notebooks, Desktops, and Servers
- Portable Instrumentation
- Digital Cameras
- MID/CAR DVD/MP3/MP4/PMP Players

Order information

Device	Marking	Package	Shipping
ESD12B100TA	12D	SOD-523	3000/Tape&Reel

Absolute maximum ratings

Parameter	Symbol	Rating	Unit
Peak pulse current ($t_p = 8/20\mu s$)	I_{PP}	5.0	A
ESD according to IEC61000-4-2 air discharge	V_{ESD}	± 30	kV
ESD according to IEC61000-4-2 contact discharge		± 30	
Operation junction temperature	T_J	-55~150	$^{\circ}C$
Lead temperature	T_L	260	$^{\circ}C$
Storage temperature	T_{STG}	-55~150	$^{\circ}C$

Electrical characteristics (TA=25 $^{\circ}C$, unless otherwise noted)

Parameter	Symbol	Condition	Min.	Typ.	Max.	Unit
Reverse stand-off voltage	V_{RWM}				± 12.0	V
Reverse leakage current	I_R	$V_{RWM} = 12.0V$			0.5	μA
Reverse breakdown voltage	V_{BR}	$I_T = 1mA$	13.0			V
Clamping voltage	V_C	$I_{pp} = 1A$ $t_p = 8/20\mu s$			17.0	V
		$I_{pp} = 5.0A$ $t_p = 8/20\mu s$			23.0	V
Junction capacitance	C_J	$V_R = 0V, f = 1MHz$		10.0		pF

Electrical performance curve

- V_C : Maximum clamping voltage
- V_{br} : Reverse breakdown voltage
- V_{RWM} : Working voltage
- I_{PP} : Maximum peak current

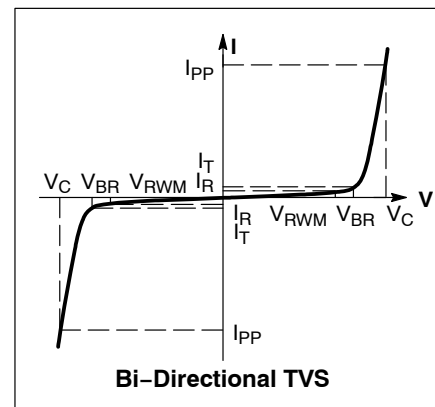

Typical characteristics ($T_A=25^\circ\text{C}$, unless otherwise noted)

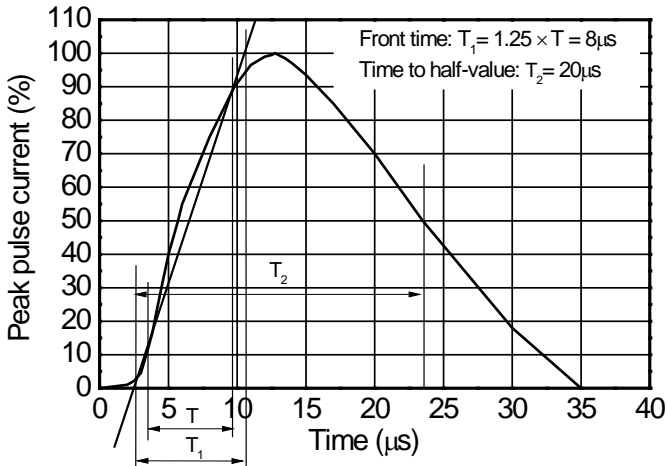

8/20 μs waveform per IEC61000-4-5

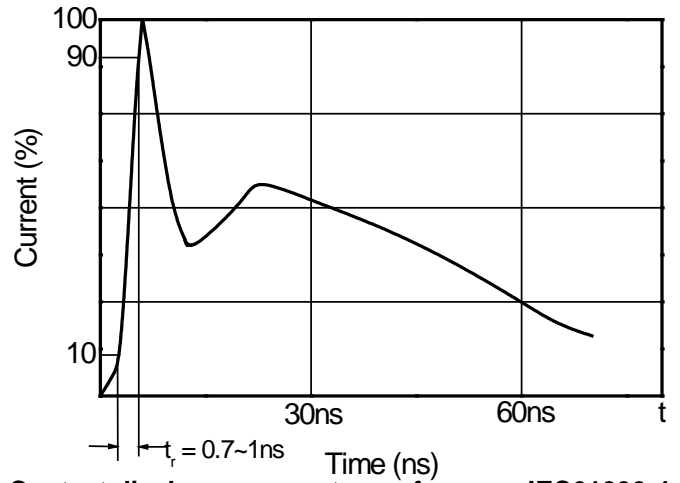

Contact discharge current waveform per IEC61000-4-2

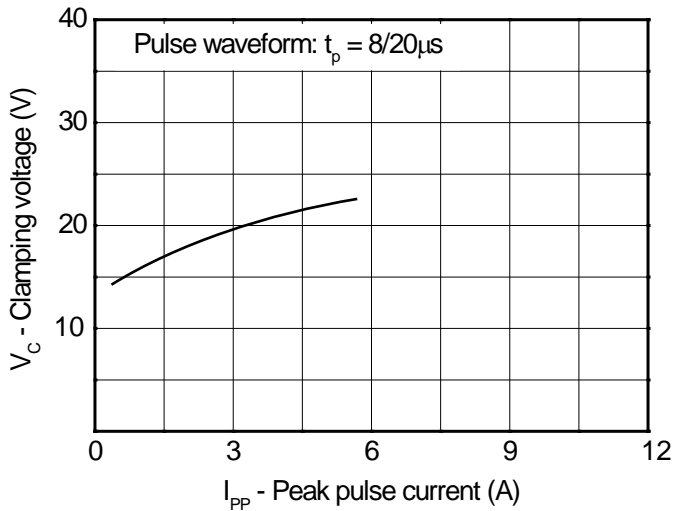

Clamping voltage vs. Peak pulse current

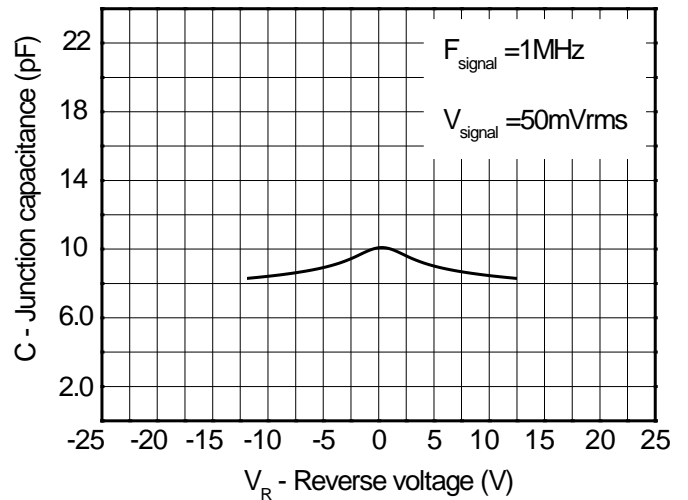

Capacitance vs. Revers voltage

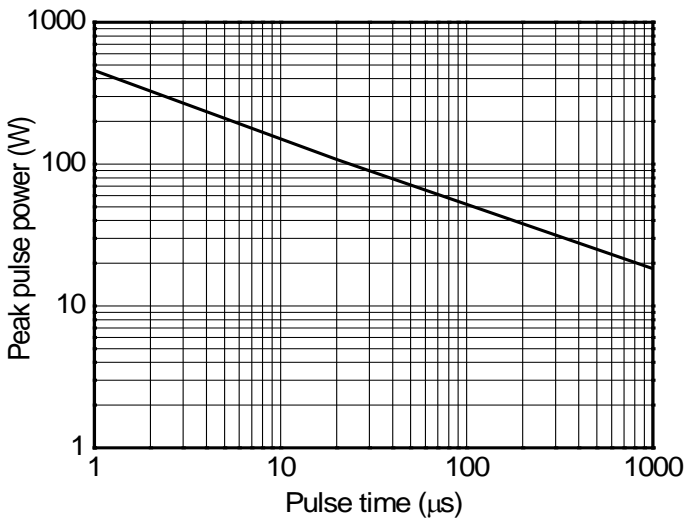

Non-repetitive peak pulse power vs. Pulse time

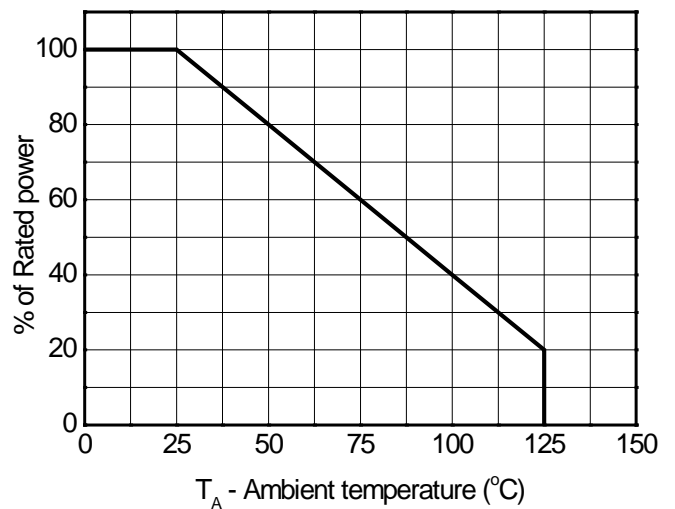

Power derating vs. Ambient temperature

ESD clamping test setup and waveforms

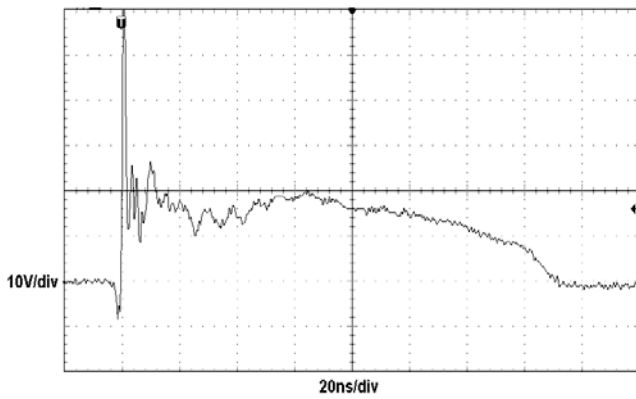
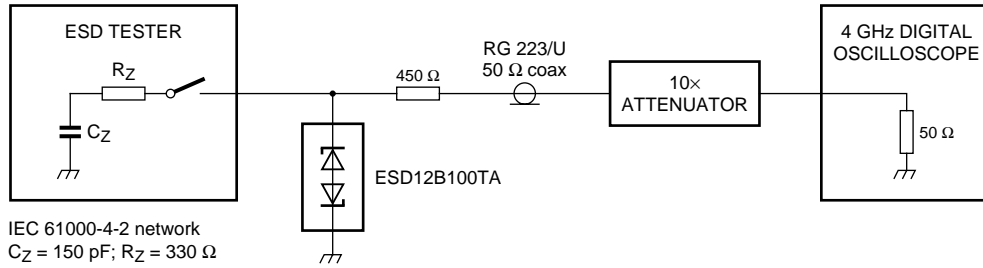

ESD clamping
 (+8kV contact discharge per IEC61000-4-2)

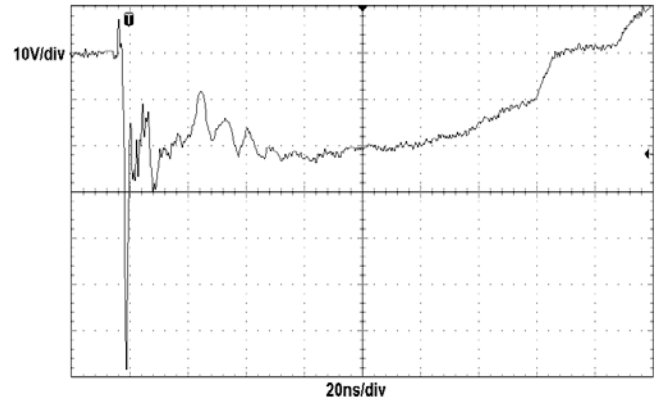

ESD clamping
 (-8kV contact discharge per IEC61000-4-2)

Package outline dimensions

SOD-523 Package Outline Drawing

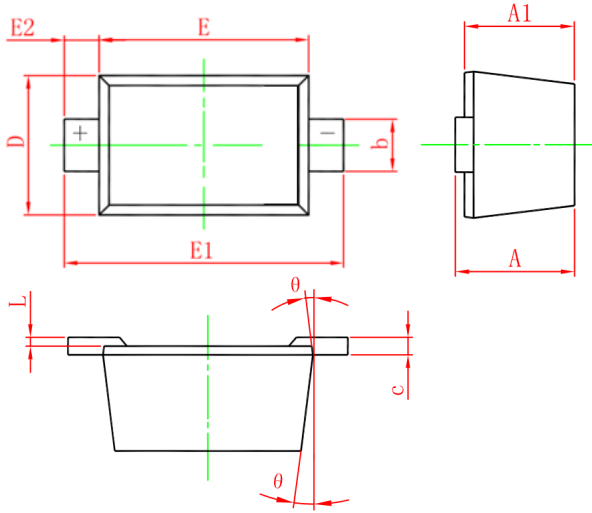

SYM	DIMENSIONS					
	MILLIMETERS			INCHES		
	MIN	NOM	MAX	MIN	NOM	MAX
A	0.51	--	0.77	0.020	--	0.031
A1	0.50	--	0.70	0.020	--	0.028
b	0.25	--	0.35	0.010	--	0.014
c	0.08	--	0.15	0.003	--	0.006
D	0.75	--	0.85	0.030	--	0.033
E	1.10	--	1.30	0.043	--	0.051
E1	1.50	--	1.70	0.059		0.067
E2	0.20REF			0.008REF		
L	0.01	--	0.07	0.001	--	0.003
Θ	7° REF			7° REF		

Suggested Land Pattern

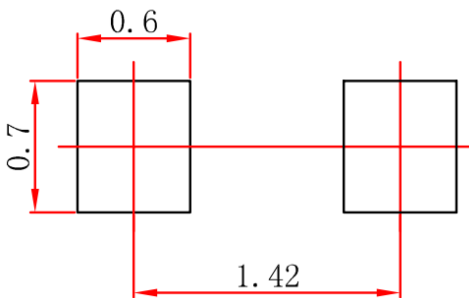

Unit : mm